

INSTALLATION & MAINTENANCE FOR BT-SERIES ASSEMBLIES

I. OVERVIEW OF FUSIBLE LINK ASSEMBLIES

AVK Carbo-Bond fusible link valve assemblies are designed for flow shutoff protection in piping systems handling flammable gasses or liquids, solvents, toxic fluids, or any other potentially dangerous media. These fire control valves terminate flow in the event of fire, aiding in reducing fire intensity. In the event of fire, the fusible link separates, allowing the top mounted spring pack to drive an API607 fire safe rated valve into a closed position. Fusible links are available in a range of temperature settings. The fusible link valve assembly also is available in a fail open position, ideal for a sprinkler system in the event of a fire.

The fusible link assembly you have received has been assembled and tested at our factory with attention to safety in mind. AVK Carbo-Bond uses high quality materials and tested engineering to ensure that this product will operate safely and reliably. Carefully read all instructions before handling in order to avoid injury to the operator or damage to the product.

NOTE: Please refer to the attached assembly drawing FL-BT-0600 for parts identification and complete parts list.

II. GENERAL SAFETY INSTRUCTIONS

WARNING: This fusible link assembly may have been shipped from the factory in the armed position and is ready for installation in line. Use extreme caution in handling the assembly because the spring pack is under full tension at all times. **NOTE: Ball valves are shipped in the OPEN position; high performance butterfly valves are shipped in the CLOSED position.**

The unit must be installed in a location with carefully maintained ambient temperatures. Installing the link in locations where high temperature fluctuations are possible (such as direct sunlight) is not recommended. Exposure to high ambient temperatures can cause the fusible links to break prematurely. (See chart 1 for link temperature ratings.)

chart 1

Part Number	Yield Temp.	Max. Ambient Temp.
WS2-72	162° F/72° F	109° F/42° C
WS2-93	200° F/93° C	145° F/63° C
WS2-141	286° F/141° C	232° F/111° F
WS2-182	327° F/182° C	305° F/152° C
WS2-227	440° F/227° C	386° F/197° C

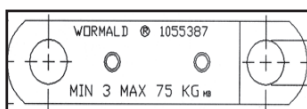

illustration 1.2

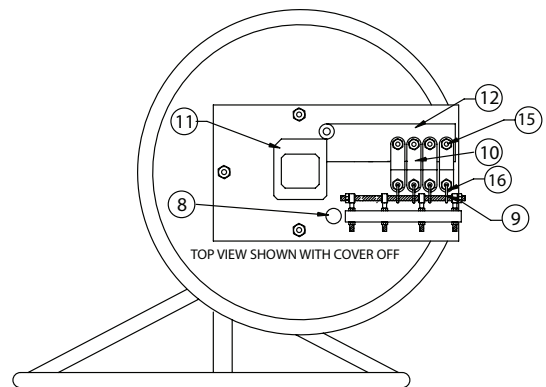

ILLUSTRATION 1.1

all reference numbers refer to drawing FL-BT-0600

INSTALLATION & MAINTENANCE FOR BT-SERIES ASSEMBLIES

III. INSTALLING FUSIBLE LINKS ON THE HEAVY DUTY SERIES ASSEMBLY

NOTE: UNITS WITH BALL VALVES ARE SHIPPED IN THE ARMED (OPEN) POSITION AND ARE SET AFTER THE DECLUTCH IS DISENGAGED. UNITS WITH HIGH PERFORMANCE BUTTERFLY VALVES ARE SHIPPED IN THE CLOSED POSITION, AND MUST BE MOVED TO THE OPEN POSITION AND ARMED.

FOR ARMED ASSEMBLY (BALL VALVES)

REQUIRED TOOLS: none

NOTE: INSTALL VALVE IN PIPELINE BEFORE PROCEEDING!

1. With declutch engaged, turn declutch handwheel clockwise (CW) until spring tension is held by links.
2. Disengage declutchable manual override gear by turning the declutch gear handwheel slightly toward the closed position (CW). The handwheel should move freely and not cause the valve to turn. (Refer to page 3 drawing for engaged/disengaged positions on declutch gear.)
3. The unit is now armed.

FOR UNARMED ASSEMBLY (BUTTERFLY VALVES)

REQUIRED TOOLS: 9/16" open-ended wrench to install nuts (varies with spring pack)

NOTE: INSTALL VALVE IN PIPELINE BEFORE PROCEEDING!

1. Move locking trigger (#12) away from spring pack stop assembly (#11) prior to opening valve.
2. Engage declutchable manual override gear and open valve. (Refer to page 3 drawing for engaged/disengaged positions on declutch gear.)
3. Turn the declutch gear handwheel toward the fully open position (CCW) before arming with fusible links.
CAUTION: Keep declutch in engaged position at this time.
4. After valve has been opened, swing locking trigger (#12) into position as shown on illustration FL-HT-0600-1.1 on page 3.
5. Place fusible link rod end connectors through holes on spring pack arming device (#7). IMPORTANT: Keep fusible links (#10) straight while attaching rod end connectors.
6. Place nuts and washers on connecting rods. Adjust rod end nuts until a slight tension on the links is felt. DO NOT OVERTIGHTEN.
7. With declutch engaged, turn declutch handwheel clockwise (CW) until spring tension is held by links. Disengage declutch mechanism according to instructions on page 4. DO NOT FORCE INTO POSITION. The unit is now armed.

IMPORTANT: THE UNIT IS NOT ARMED UNTIL THE GEAR HAS BEEN PLACED IN THE DISENGAGED POSITION AFTER INSTALLATION OF LINKS. IF THE GEAR IS LEFT IN THE ENGAGED POSITION THE VALVE WILL NOT SPRING CLOSE.

IV. OPERATION

Once the unit is properly armed, the valve may be operated closed-open in the normal manner using the declutchable gear handwheel upon removal of the fusible links (reverse "Installation" instructions above). The gear lever must always be returned to the DISENGAGED position after manually operating the valve and the links must be put back into place. Failure to return the gear to the disengaged position will lock the gear and valve into position, and the fusible link assembly will not function properly.

IMPORTANT: THE FUSIBLE LINKS MUST BE RETURNED TO THE ARMED AND INSTALLED POSITION AFTER MANUAL OPERATION!

INSTALLATION & MAINTENANCE FOR BT-SERIES ASSEMBLIES

V. MAINTENANCE

IMPORTANT: The fusible link manufacturer recommends annual replacement of link(s) as part of a regular maintenance schedule. Contact your local distributor or AVK Carbo-Bond for replacement links. Order by part number or temperature rating on old link. Replacement valve seats and seals subject to normal wear are available from your local distributor or AVK Carbo-Bond. The spring case and declutchable gear are lifetime lubricated and do not require maintenance. Disassembly of the spring case or gear will void any written or verbal warranties.

WARNING: THE SPRING CASE CLOCKSING IS ALWAYS UNDER PRESSURE. DO NOT DISASSEMBLE SPRING PACK UNDER ANY CIRCUMSTANCES. DISASSEMBLY OF THE SPRING PACK COULD RESULT IN SERIOUS INJURY OR DEATH.

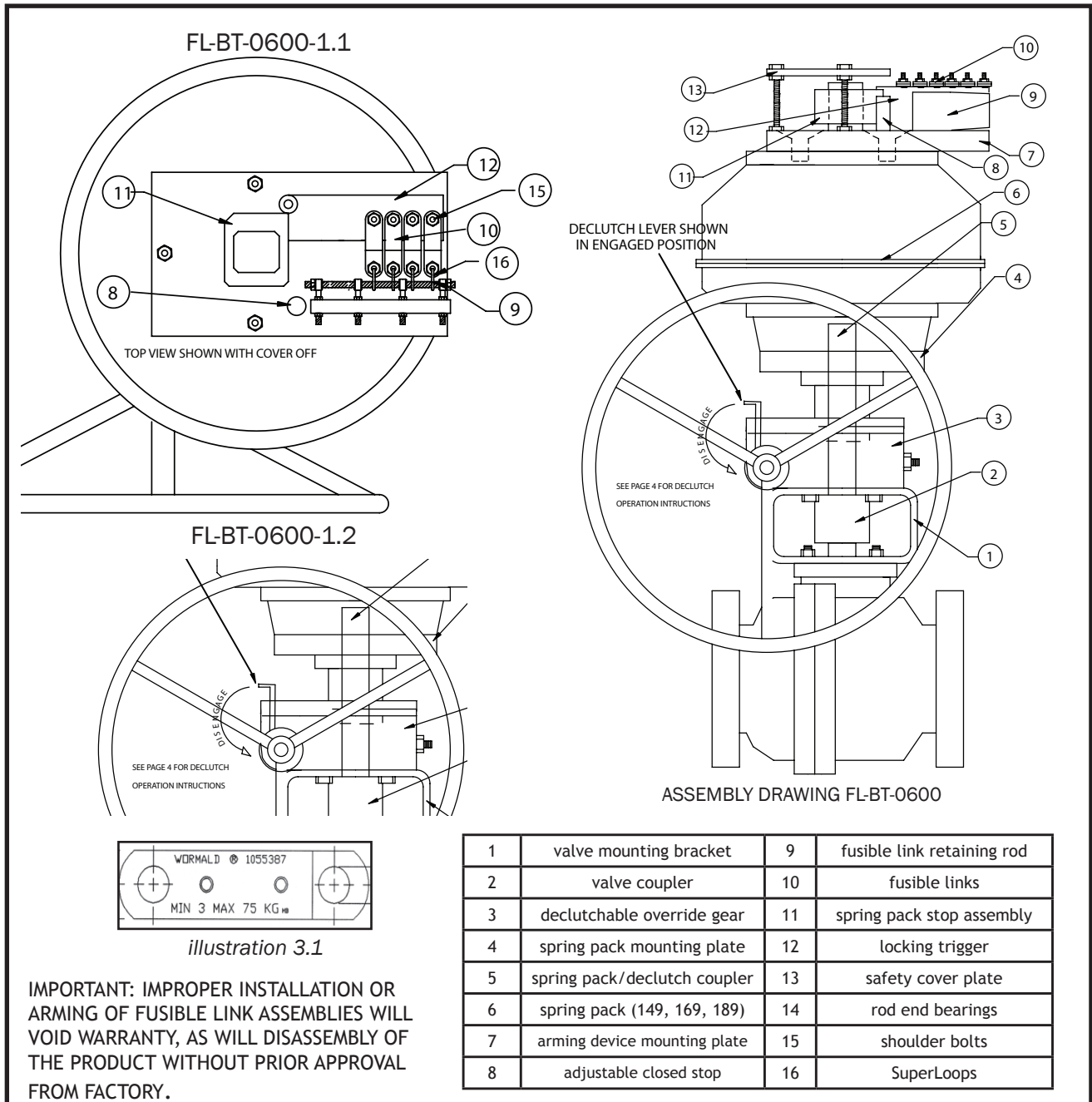

INSTALLATION & MAINTENANCE FOR BT-SERIES ASSEMBLIES

VI. OPERATING THE DECLUTCHABLE MANUAL OVERRIDE GEAR

IMPORTANT: Make sure that the fusible links have been removed before attempting to operate the valve with the declutchable manual override.

Use the following instructions to **ENGAGE** the declutchable manual override.

1. Using one hand, grab the override engagement handle, squeezing the bottom handle and top handle together.
2. With the handles still squeezed together, rotate the handle from its declutched position upward toward the spring pack mounting flange until the handle locking tabs are in line with their locking positions.
NOTE: In some cases the override gear teeth will not mesh correctly when rotating the handle upward. If this occurs, rotate the override handwheel slightly to mesh the gears and then rotate the declutch handle upward.
3. Once the override handle is in its locked position, the override is ready to be used. Clockwise rotation of the override handwheel will produce clockwise rotation of the override output and valve. Conversely, counterclockwise rotation of the handwheel will produce counterclockwise rotation of the override output, and valve.

Use the following instructions to **DISENGAGE** the declutchable manual override.

Note: When the assembly is rearmed with the fusible links back in place, the the manual override must be returned to its declutched position. Reversing the procedure above will return the override to the declutched position. Make sure that the handle locking tabs are inserted into their locking position on the override housing.

Leaving the declutch engaged will prohibit the spring return unit from cycling the valve to the closed position when the fusible links yield. Leaving the unit in the engaged position will prevent the unit from operating correctly, may cause damage to the override as well as drivers linkages, etc. and void the override warranty.

IMPORTANT: The fusible links will have to be reinstalled and the declutch disengaged before the assembly is properly armed.



DISENGAGED

The picture on the left shows the declutch operator in the disengaged to allow the spring pack to close the valve when the fusible links yield. As shown, the handle arrangement is pinned in the down position. The handwheel should rotate freely in either the clockwise or counterclockwise directions without affecting the valve rotation.



ENGAGED

The picture on the left shows the declutch in the “override” position, or “engaged,” for operating the valve manually. As shown, the handle arrangement is pinned in the up position for override. Rotation of the handwheel clockwise will rotate valve clockwise (generally closed direction); rotation of the handwheel counter-clockwise will rotate actuator counterclockwise (generally open).

IMPORTANT: FUSIBLE LINKS MUST BE REMOVED BEFORE ATTEMPTING TO OPERATE THE VALVE WITH THE DECLUTCH.